

INTELLIGENT MESSEN!
MEASURE WITH INTELLIGENCE!

ecom[®]

English



OPERATION MANUAL

ecom[®] J2KN^{pro tech}

Content

Safety Instructions	4
1. Instrument Design.....	6
1.1. Basic module	6
1.2. Control Module	8
2. Gas Flow Scheme	9
3. 2-stage Peltier Cooler	10
4. Heated Sampling System	11
4.1. Connection Heated Sampling System.....	11
4.2. Heated Hose.....	11
4.3. Heated Head.....	12
4.3. Heated head with heated tube.....	13
5. Converter	13
6. Power supply	15
7. Radio communication basic control module	16
8. Data record	17
9. Starting.....	18
10. Input or select plant specific data	20
11. Flue gas analysis	23
11.1. Gas analysis	23
11.2. Flow measurement	26
11.3. Pressure measurement	27
11.4. Soot...Oil trace	28
11.5. Measurement record and printout	30
11.6. Mean value measurement	31
11.7. After measurement	33
12. Adjustments	34
13. Control	40
14. Data Processing	42
14.1. Communication.....	42
14.2. Automatic measurement.....	43
14.3. Data logger	44
14.4. Data logging with DASNT2.....	45
14.5. Data processing with DAS5.....	45
14.6. Data processing with App.....	46
15. Diagnostics	46
15.1. Fault diagnostic.....	46
15.2. dT measurement.....	49
16. Maintenance Tipps	50
17. FAQ.....	55
18 Technical Data.....	56

Congratulations!

With your purchase you have decided on a high-quality product of ecom GmbH.

Get to know the product before you start using it while reading carefully the following instructions of use and the safety indications. Use the product only as described and only for the given areas of application in order to ascertain its longevity.

Safety Instructions



WARNING

Risk of Poisoning

Poisoning can result from flue gas.

Connect flue gas hose to flue gas duct before starting!

Please confirm after successful connection the security message at the instrument with **<OK>**.

Security message:

Please confirm (OK) before starting, that the sample gas outlet (TOXIC GAS) has been connected through the flue gas hose to the flue gas duct!

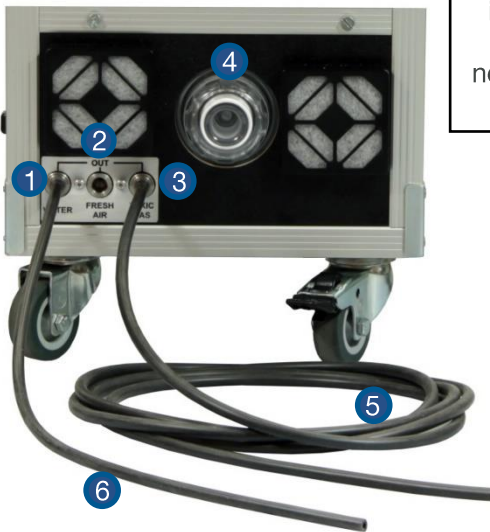

1	Condensate outlet	3	Sample gas outlet (TOXIC GAS)	5	Flue gas hose
2	Fresh air connection 2	4	PTFE Filter 2	6	Condensate hose



WARNING

Hazard of Injury

Improper work on incinerators can cause injuries.

Work on incinerators may only be done by qualified specialists.



WARNING

Hazard of Electric Shock

When the housing is open, electrically components are exposed.

Before opening the unit, disconnect it from the power supply.



CAUTION

Impaired Device Function

To ensure sufficient airflow, a minimum distance of 0.5 m must be kept to walls or objects!



CAUTION

Damage to Electronic Components

Electrostatic discharge can cause damage to electronic components. Touch a grounded component before touching the inside of the housing.



CAUTION

Damage of the Sensors

Substances containing solvents damage the device's sensors.

Avoid contact with substances containing solvents.

NOTICE

Strong electromagnetic fields can affect the function of the device.
Do not expose the device to strong electromagnetic radiation.

NOTICE

Before starting connect the condensate hose
(possibly collect condensate in a vessel)!

1. Instrument Design

1.1. Basic module



1	Heated head	3	Radio antenna	5	Printer
2	Heated hose	4	Gas cooler 1	6	Control module



7	Power supply	9	Connection gas temperature	11	Connection draught
8	Connection heated probe	10	Connection sample gas	12	Connection pressure

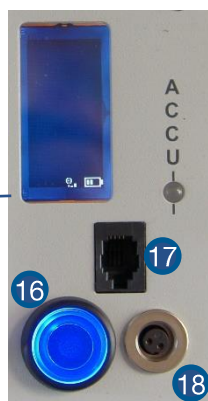

13	PTFE filter 1	15	Info display	17	Connection to control module
14	SO ₂ /NO _x filter	16	On/Off Basic module	18	Connection 1 air temperature

1.2. Control Module



1	Connection 2 air temperature	6	Store key	11	Connection to keyboard
2	BLE-antenna (Option WLAN)	7	Cursor keys	12	Display light On/Off
3	Slot for Multi-Media Card	8	ESC key	13	OK key
4	Display	9	On/Off control module	14	Print key
5	Function keys	10	Connection to basic module	15	Connection USB

2. Gas Flow Scheme

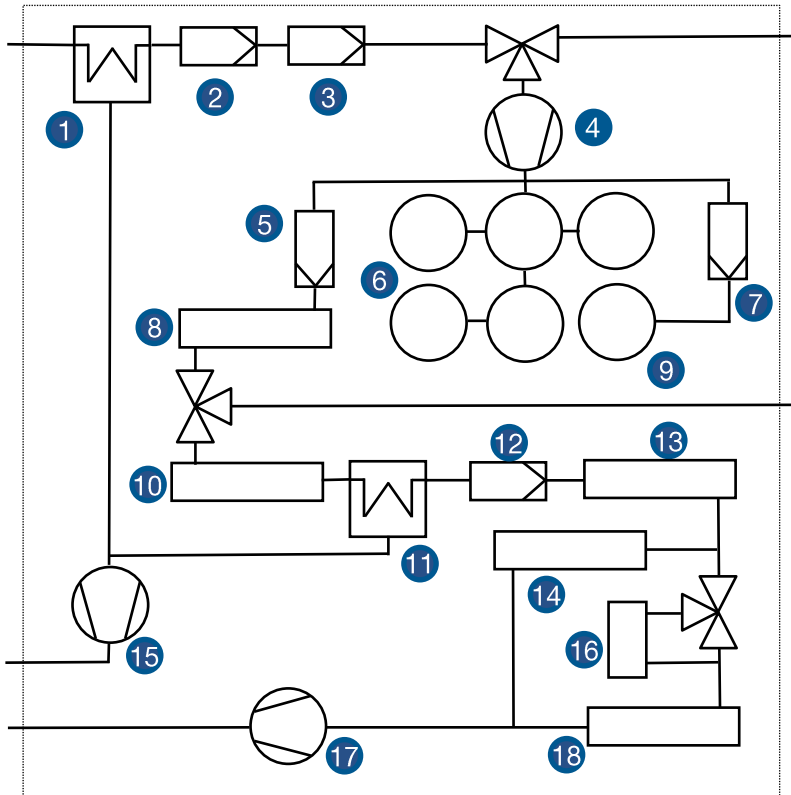

1	Gas cooler 1	7	NO _x /SO ₂ filter	13	NDIR 2
2	Fine dust filter	8	NDIR 1	14	PAS-Modul
3	Safety filter	9	EC-Sensor CO	15	Condensate pump
4	Gas pump 1	10	NDUV	16	Converter
5	PTFE filter 1	11	Gas cooler 2	17	Gas pump 2
6	Electrochemical sensors	12	PTFE filter 2	18	CLD

3. 2-stage Peltier Cooler

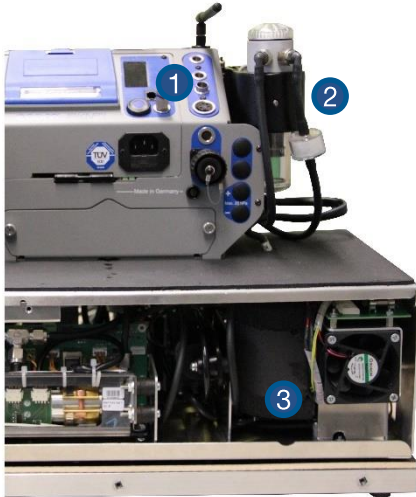

1	Gas inlet	2	Gas cooler 1	3	Gas cooler 2
---	-----------	---	--------------	---	--------------

Flue gas with a temperature above the dew point is sucked spiral via a long gas path thru a surface coated metal body with good thermal conductivity. The gas radiates its heat to this metal body A Peltier element (semiconductor cooling element) flown by a continuous current is thermally connected with this body and with a second metal body with cooling ribs and ventilation slots. The current thru the Peltier element creates a heat transfer from hot to cold, drains the heat of the metal body flown by gas and transfers it to the outer cooling body. This heat is transferred thru ventilation to the surrounding air.

The condensation issued by the heat loss of the gas drops in a receptacle and is pumped out by a permanent working hose pump. The sucking capacity of the gas conveying pump avoids a sufficient dwell time of the gas with the condensate, so that wash out reactions ($\text{NO}_2 + \text{H}_2\text{O} > \text{H}_2\text{NO}_3$) do not take place. At the cooler outlet the gas has a temperature of ca. 5 °C with a relative saturation of nearly 100 % relative humidity (corresponds to a water steam content < 7 g/ m³).

4. Heated Sampling System



By using a heated sampling system is possible to measure water-soluble substances (NO_2 and SO_2) without washout. A built-in hot gas filter protects the instrument especially for long-term measurements from fouling. The maximum exhaust gas temperature when using the heated sampling system is 500°C .

4.1. Connection Heated Sampling System



The heated sampling system can be used in combination with the ecom-J2KNpro tech. To do this, the heated hose is connected as shown in the picture.

4.2. Heated Hose



The heated hose is available in lengths of 3.4 m, 5 m, 7 m, 10 m and 15 m. The heated hose can be set to a maximum temperature of 180°C .

NOTICE

Do not bend the heated hose!

Heated hose has to be cooled out after the measurement!

Heated hose may not be folded too tight - use the whole case!

Do not put the heated hose in water!

4.3. Heated Head

The heated head (BK2) is available with probe lengths of 300 mm, 500 mm, 700 mm, 1,000 mm and 1,500 mm including a thermocouple. The PTFE filter can be changed as follows:



1. Disconnect connections to heated hose.
2. Loosen the bayonet lock on the back of the heated head.
3. Remove the filter carefully.
4. Insert new filter and fix with bayonet lock.
5. Make connections to heated hose.

NOTICE

Clean or change the PTFE filter regularly!

4.3. Heated head with heated tube



The heated sampling tube has a diameter of 25 mm and is 1 m long. The power supply for the heating is ensured by a 4 m long connection cable. The temperature control is housed in the attached junction box. The temperature can be set between 100 °C and 180 °C. The maximum exhaust gas temperature for using the heated sampling tube is 400 °C.

5. Converter

The NO₂ / NO converter converts catalytically the NO₂ content of the sample gas into NO. For this purpose, the sample gas is passed through a converter cartridge from stainless steel having a catalyst filling. This conversion allows an indirect measurement of NO₂ (switch function key <F1> at the control unit to toggle between NO and NO_x measurement).

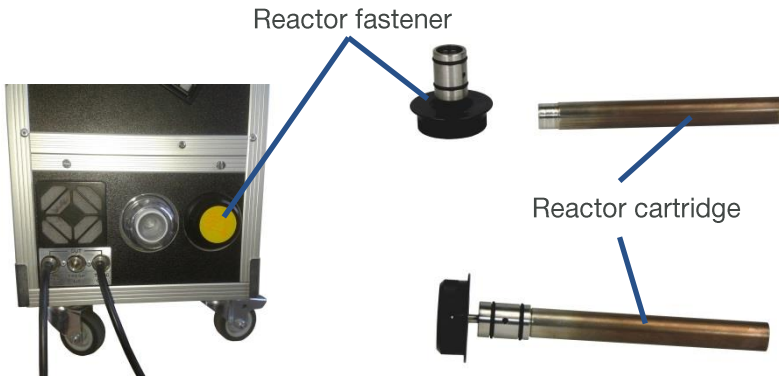

Replace reactor cartridge:



WARNING

Hazard of burning

The converter cartridge is hot! Touching may cause severe burns!
Wear suitable protective gloves and protect the converter cartridge against access!

Replace the reactor cartridge if the conversion rate from $\text{NO}_2 \Rightarrow \text{NO}$ falls below the required value. Changing the reactor cartridge is possible without tools in a very short time. We recommend turning off the instrument and letting cool down for approximately 1 hour before changing the cartridge. This minimizes the hazard of burning. There is also the possibility of changing cartridges in a heated instrument, but the converter cartridge has a temperature of about 200°C .

How to change the reactor cartridge:

1. Stop sample gas flow (deactivate NO_x measurement).
2. Before opening the reactor fastener make sure that no toxic or dangerous gases or components are provided within the gas way (Purge the tubes with inert gas or air).
3. Turn the reactor fastener counter anticlockwise up to the end of the thread.
4. Pull out the fastener with the reactor cartridge carefully. Let the cartridge cool down if needed.
5. Pull the reactor cartridge out carefully from the reactor fastener (wear protective gloves).
6. Replace new reactor cartridge to the reactor fastener.
7. Push the cartridge carefully to the reactor opening and turn the reactor fastener clockwise up to the end of the thread.

6. Power supply

The basic module of the ecom-J2KNpro tech is delivered with internal loading unit. The connection of the power plug is needed to operate the instrument.

The control module of ecom-J2KNpro tech is powered by 3 nickel-metal-hydride accumulators (type AA). In case of need, the accumulators can be recharged by docking the control module to the basic module.



CAUTION

Damage of device

Never use batteries, to operate the control module of the ecom-J2KNpro tech!

7. Radio communication basic control module



Unlocking

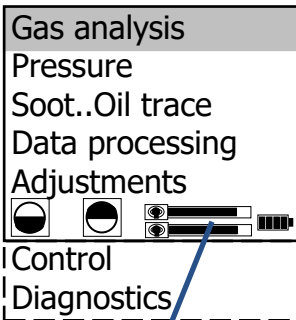

Bar indication
radio quality

Thanks to the detachable control module the basic module can be monitored wireless. The basic module can be unlocked as follows:

1. Actuate unlocking
2. Tip control module forwards
3. Release control module from basic module

The information exchange between control and basic module is performed via radio transmission (868 MHz) with coverage of approx. 70 m (by free sight). The quality of the radio transmission is documented by a bar indication in the main menu of the instrument (long bar = good radio communication).

By interruption of the radio communication, an error message is displayed. By persisting disturbances of the radio communication, a cable (option) can take over the transfer (connection between socket DATA on control unit and socket DATA on basic module).

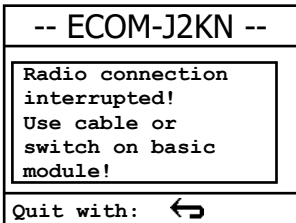

If the basic module is switched off and the control module not, so the display will show an error message inviting to fix the control module in its docking station (helps also not to forget the control module). Observe this order, quit with <ESC> and finally switch off the control module.

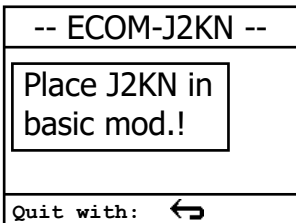

8. Data record

The multi-media card enables the storage of both punctual measurements and data logger records. The values of punctual measurements are written in a text file (J2KDV.txt). Those of data logger records in a csv file (J2KDL-xx.csv / xx = records numbered consecutively). Both file types have the same structure and can be imported respectively opened in Excel. See chapter „Technical Data“ for data format information. The files can be transferred on the PC using a card reader.

NOTICE

The SD card must have the following properties:

min. card volume 32 MB - max.32 GB (UHC)

card formatted on 16-bit FAT or FAT32



Insert memory card

Insert the multi-media card as shown. Take care that the card does not stand out and hooks on.



CAUTION

Data loss

Never put out cards during data record - data loss and damage of the data carrier possible!

9. Starting

NOTICE

Before starting up please remove the transport protection!

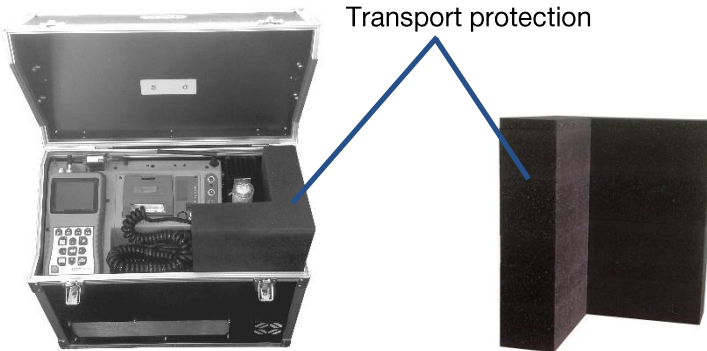

Once the control module has been switched on (key <I/O>), the main menu is displayed.

8 sub-menus with the following functions are displayed (non-visible sub-menus can be called up scrolling the arrow keys):

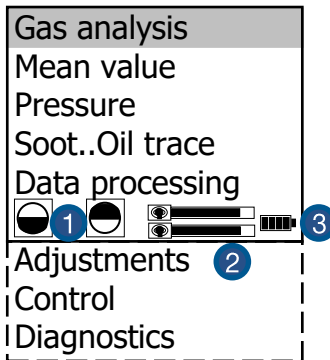

1

Contrast adjustable with F1 and F2

2

Bar indication radio and transfer quality

3

Battery voltage (charging status)

1. Gas analysis: Perform gas analysis.
2. Mean value: Measurement with mean value calculation.
3. Pressure: Perform draught or pressure measurement.
4. Soot...Oil trace: Input of soot measurements results.
5. Data processing: Assign measurements / Load or send data.
6. Adjustments: Modify instrument adjustments.
7. Control: Check operation state of instrument.
8. Diagnosis: Read-out of firing automats (only in connection with ecom-AK) / dT-measurement.



CAUTION

Wrong measurement results

Make sure that the instrument is turned on in clean air, because the zero point of the sensors will be updated with fresh air!

If measurements are carried out first the basic module has to be turned on (switch below the info display). Select the sub-menu "**Gas analysis**" with the cursor keys and confirm with **<OK>**. The instrument starts with a warm-up phase (max. 30 min.). After the sensors are at operating temperature, a 15-minute stabilization phase follows followed by a 3-minute calibration with fresh air. Simultaneously, the message appears asking if you want to use the data processing. If you want to assign the sampled data to a specific plant, so press **<F1>** (**<F4>** = no: measurement will be performed without assignment).

Fuel type		
Fuel oil (B)		
CO2max	A1	B
15.4	0.50	0.007
Select:		

Fuel types acc. to 1st BImSchV*:

Fuel oil (B)
 Natural gas (B)
 City gas (B)
 Coke oven gas (B)
 Liquid gas (B)

* Country specific fuel types programmable on demand

Use the cursor keys to select the desired fuel type and confirm with **<OK>**.

10. Input or select plant specific data

To call up plant data recorded in the device or to create a new file, the following possibilities are available:

Selection upon:
Search word
Memory number
Create new
Quit with: 

Create new (is automatically selected by first use of a MM card):





To create a new file, a numerical number can be assigned. Proceed as follows:

1. Select „**Create new**“.
2. Confirm with **<OK>**.
3. Input a number (max. 16 numbers).

Input number
25.11.2017
Please use the numeral keys!

Example: "25.11.2017"

Tip: We suggest a date-related input to easily find the data record later on via the search function (search per date).

Insert Text
25.11
A B C D E F G H I J K L M N O P Q R S T U V W X Y Z Ä Ö Ü . - () [] { }
   

After confirming with **<OK>** it is possible to enter a text (max. 6 lines with 20 indications) with a software keyboard (for print out or data processing).

Proceed as follows:

1. Choose Text line 1 with the cursor keys **<up/down>** and confirm with **<OK>**.
2. Select keyboard (4 keyboards are available) with **<F3>**.
3. Select with the cursor keys **<up/down/right/left>** a character (selected character is black deposited).
4. Choose the character with **<OK>** (the last character can be deleted by pressing **<F2>**).
5. Repeat procedure, until line is complete.

If you want to correct a character, proceed as follows:

1. Interrupt choosing characters with **<F4>**.
2. Select character with the cursor keys **<right/left>**.
3. Activate choosing characters with **<F4>** and set a new character.
4. Select the next line after pressing **<F1>**.

Close the text input with **<ESC>**. Activate the next free memory number with **<OK>** and start flue gas measurement with **<F1>**.

Selection upon:
Search word
Memory number
Create new
Quit with: ←

Memory number
1
Please use the numeral keys!

Memory number:

For check of the plant already stored in the instrument, the selection upon memory number is most appropriate. Proceed as follows:

1. Select „**Memory number**“
2. Confirm with **<OK>**.
3. Input a random memory number:

Example: "1" for memory number 1

Press **<OK>** once the input is completed to call up said data memory number.

- The cursor keys **<Up/Down>** enable the check of the memory numbers.
- Press **<F1>** to select the first memory number and **<F2>** for the last.
- Press **<F4>** to delete the content of the selected memory number.
- Press **<OK>** to activate the memory number.

Finally press **<F1>** to start the gas analysis.

Search word: If the plant code is known, it is possible to find the plant data stored with help of a search machine. Select "Search word" and press <OK>. Input with software keyboard 4 related figures of the plant code:

Search word												
25.11												
A	B	C	D	E	F	G	H	I	J	K	L	M
N	O	P	Q	R	S	T	U	V	W	X	Y	Z
Ä	ö	ü	.	-	()	[]	{	}		
<input checked="" type="checkbox"/>	<input type="checkbox"/>	<input type="checkbox"/>	<input type="checkbox"/>	<input type="checkbox"/>	<input type="checkbox"/>	<input type="checkbox"/>	<input type="checkbox"/>	<input type="checkbox"/>	<input type="checkbox"/>	<input type="checkbox"/>	<input type="checkbox"/>	<input type="checkbox"/>

Example: "25.11"
for plant code 25.11.2017

Press <F1> after input to start the searching process. All possible correspondences with these figures sequence will be filtered. The selection can be stepped thru with the arrow keys (<F1> for selection beginning, <F2> for selection end). Press <OK> to activate once the desired data block is found. Press „View“ / <OK> to view the previous analysis at this plant. All measured and calculated values can be called up on 5 display pages using the arrow keys to step thru.

Memory number 1	
25.11.2017	
F1:First record	
F2:Last record	F4:Delete
End with :	<input checked="" type="checkbox"/> !

Measurement available

Memory number 1	
25.11.2017	
Data record	12:15:53 25.11.17
Further pages:<↑>	Memory number 1

O2	3.2 %
CO2	13.1 %
CO	0 ppm
Eff.	92.5 %
Losses	7.5 %
Exc. air	1.18
T.Gas	184.4 °C
T.Air	20.3 °C
Zug	-0.03 hPa
Gas analyses	12:15:53 25.11.17
Further pages:<↑>	Memory number 1

O2	17.5 %
CO 0%	738 ppm
CO	123 ppm
Exc. air	7.00
CO-Measurement	12:15:53 25.11.17
Further pages:<↑>	Memory number 1

O2 value in air	
O2	19.5 %
CO	3 ppm
Zug	0.01 hPa
O2 value in air	12:15:53 25.11.17
Further pages:<↑>	Memory number 1

Soot..Oil trace	
Boiler temp. :	65 °C
1.Soot meas. :	0.5
2.Soot meas. :	0.3
3.Soot meas. :	0.7
Oil trace :	NEIN
Mean value :	0.5

dT measurement	
T1	70.4 °C
T2	56.3 °C
dT	14.1 °C
dT measurement	12:15 25.11.17
Further pages:<↑>	Memory number 1

Press <F1> to quit the previous measurement and start recording of the current measurement values.

11. Flue gas analysis

11.1. Gas analysis



CAUTION

Wrong measurement results

To compensate a possible sensor drift, it is important to calibrate the instrument with fresh air at regular Intervals!

After warm-up and calibration phase, the instrument switches over to the measurement mode. The gas measurement values can be viewed on different display pages. Use the cursor keys to scroll the pages.

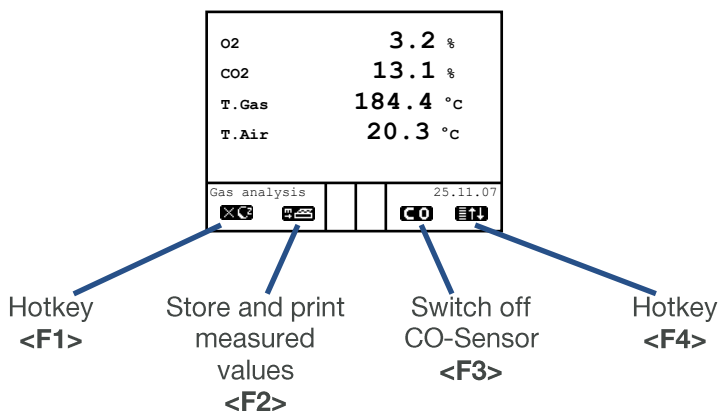

With <F1> you can switch from the measured value display to a menu or selected before (see chapter Adjustments). Possible menu options are: Soot... Oil trace, Data processing, Adjustments, Control, Fuel type, Standby, Purge, Eff. (C), Memory -> M, CLD NO <-> NO_x, WLAN, Pressure. Further you can switch with <F1> from any menu back to the measured value display.

With <F2> you can print and store the measured values into the intermediate memory at the same time.

With <F3> you can switch off the CO sensor, in order to protect the sensor against too high concentrations (only required for electro-chemical CO sensor). The automatic disconnection will switch off the CO sensor at approx. 2500 ppm (also for CO IR).

With **<F4>** you can switch from the measured value display to a menu selected before (see chapter Adjustments). Possible menu options are: Soot... Oil trace, Data processing, Adjustments, Control, Fuel type, Standby, Purge, Eff. (C), Memory -> M, CLD NO <-> NOx, WLAN, Display values, Pressure. Further you can switch with **<F1>** from any menu back to the measured value display.

The position of the measured and calculated values (gas analysis) on the display pages is free selectable (choose „**Display values**“ for **<F4>** Hotkey). For alteration of the existing succession respectively personal listing, proceed as follows:

1. Press **<F4>** to activate the function.
2. Select the line with the cursor keys **<up/down>**.
3. Select the measured or calculated value with the cursor keys **<right/left>**.
4. Repeat this procedure until all modifications are completed.
5. Press **<F4>** to deactivate the function.

Instruments with magnetic valve and fresh air connection

Instruments that are equipped with magnetic valve technology and fresh air connection are able to be purged or calibrated with fresh air without taken out the probe out of the flue gas duct:

For fresh air purging, press the **<OK>** key from the measured value display, select the menu item "Fresh air purge" and press the **<OK>** key again. The fresh air purging can be ended with **<F3>** in the measured value display.

For fresh air calibration, press the **<OK>** key from the measured value display, select the menu item "**Re-Calibration**" and press the **<OK>** key again. After the following query has been answered with "**YES**" (**<F1>**), the 1-minute calibration phase starts.

Core stream search

Position the sampling probe in the exhaust channel so that the thermocouple is fully surrounded with the gas.

Perform the measurement in the core stream of the exhaust gas channel (probe placed in the highest gas temperature area).

Core stream search

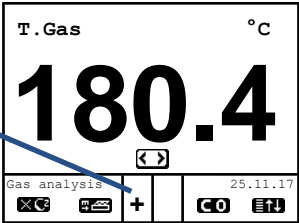

Zoom Display:
Adjust parameter
with Cursor keys
<right/left>

A trend indication for T.Gas simplifies the core stream search. As long as the display shows a + symbol, the measured temperature increases, it means the probe tip moves towards the core stream. If a - symbol is displayed, pull the probe out of the core stream and the temperature sinks. If no temperature change is shown for at least 3 seconds, so the trend indication will be deleted.

CO₂, efficiency, losses, excess air and dew point are calculated values. They can only be calculated if realistic values for the basic parameters O₂ and temperatures are available. It must be ascertained that:

$$\text{O}_2 < 20,5 \% \text{ and } \text{T.Gas} - \text{T.Air} > + 5 \text{ } ^\circ\text{C}$$

are given. The dew point can only be calculated accurately if, in the menu "Adjustments", the current barometric air pressure value has been entered. This value cannot be determined by the ecom-J2KNpro. If the gas temperature falls below the dew point (between 25 and 65 °C), ETA will be calculated with condensation. In the display (C) appears behind ETA.

Correct measurement values are displayed first after a short delay, necessary for the gas transport and the build-up of a stable electro-chemical reaction at the sensors. This time period lasts approx. between 1 and 1.5 minute. For recording, printout and evaluation wait until the values do not change anymore. If deviations higher than 2 ppm still occur by the gas values, they can be due to unstable pressure conditions in the exhaust channel.

O ₂	3.2 %			25.11.17
CO ₂	13.1 %			
T.Gas	184.4 °C			
T.Air	20.3 °C			
Gas analysis recorded!			CO	IR

Measurement stored in intermediate memory

If the measurement values are stable and the results can be printed out, press the key **<Store>** to transfer the values in the intermediate memory (caution: store gas analysis and CO measurement values separately). The values are stored for a later printout and, if need be, for a final data record storage.

If a printout of the values should be made simultaneously to the intermediate recording, so press **<F2>** (the complete content of the intermediate memory will be printed).

11.2. Flow measurement



Connections for pitot tube

Flow measurement				
V. Gas	0.4 m/sec			
M. Flow	44 Nm ³ /h			
dP	0.1 Pa			
Flow measurem. recorded!			CO	AP20

Measurement stored in intermediate memory

This measurement can be done with a pitot tube. At first the pitot factor of the pitot tube must be entered („Adjustments“ / „Internal“ / „Pitot factor“). After connecting the pitot tube to the instrument, the zero point of the sensor can be set with **<F4>**. With **<F1>** the cross section of the flow channel can be entered (needed for calculation of the flow rate). After the pitot tube is positioned in the flow channel, the display shows the speed (m/s), the flow rate (Nm³/h) and the differential pressure (Pa). If the value indicated is stable, press **<Store>** to store the value in the intermediate memory. If a printout of the values should occur simultaneously to the recording in the intermediate memory, press **<F2>** (the complete content of the intermediate memory will be printed out).

11.3. Pressure measurement

NOTICE

For this option a probe type SB is required!

A trend indication for the draught conditions in the exhaust channel can already be determined during the gas analysis. The value for the chimney draught will not be stored together with the gas values while pressing the key **<Store>**.

The difference pressure sensor tends to drifts because of its sensibility and, for an exact measurement it is consequently advised to recalibrate the sensor immediately before sampling and documenting the value.

Pressure
-0.12 hPa
Recorded value: --.-- hPa
New 0 point 

Access the menu while selecting the sub-menu "**Pressure**". The current value is displayed as well as the instruction to adjust the zero point of the sensor. Release hereto the draught hose from the instrument for a short moment and press **<F4>**. The sensor is herewith re-calibrated.

Pressure
-0.12 hPa
Recorded value: -0.12 hPa
New 0 point 

Fix the draught hose again. The display shows the exact measurement value which can be stored while pressing **<Store>** and added to the previous results in the intermediate memory. The stored value is shown on the display. Press **<ESC>** to quit the differential pressure measurement menu.

Measurement stored in intermediate memory

11.4. Soot...Oil trace

NOTICE

For this option a probe type SB is required!

Soot..Oil trace

Boiler temp. :	66°C
1st Soot meas.:	.-
2nd Soot meas.:	.-
3rd Soot meas.:	.-
Oil trace :	----
Mean value :	.-

The sub-menu "**Soot...Oil trace**" enables the input of measured results for boiler temperature, soot dots and oil trace. Select the line „**Boiler temp.**“ and press **<OK>** to activate the input. The input can be made using the numerical keys. Press **<OK>** to store the value in the data record of the measurement.

The soot dot measurement is to be performed with the optional heated pistol grip probe which heating function prevents the filter paper to become wet because of the humidity issued by the combustion condensate. The filter paper slot is hereby heated up to approx. 70 °C. Switch hereto the probe heating of the pistol grip probe while selecting „**Adjustments / Internal / Probe heating / <F1>**“. Proceed as follows:

1. Switch on the probe heating while selecting „**Adjustments / Probe heating / <F1>**“.
2. Insert a filter paper in the paper slot.
3. Select the line „**1st. Soot meas.**“.
4. Press **<OK>** to start the measurement. The display shows the volume to be sucked and the pump starts sampling.

If the soot dot analysis is made with a manual pump the sucking procedure can be interrupted while pressing **<F4>** (result value can immediately be entered).

Once 1,63 litres had been sucked in, the instrument will instruct to input the opacity degree. Proceed as follows:

1. Release the filter paper from the probe slot.
2. Compare the greyiness with the opacity scale.
3. Input the result using the numerical keys and press **<OK>**.
4. Repeat this procedure until all 3 soot dot analyses are completed.

The mean value will be calculated and automatically stored.

The result of the oil trace check is to be documented as follows:

Soot..Oil trace	
Boiler temp. :	66°C
1st Soot meas.:	1.0
2nd Soot meas.:	0.5
3rd Soot meas.:	1.5
Oil trace :	NO
Mean value :	1.0

1. Set the cursor on the line "**Oil trace**".
2. Input the result with **<OK>**
("NO", "YES" or "- - -")

Press **<ESC>** to quit the menu once all necessitated inputs have been entered. The measurement is now completed.

NOTICE

Get the probe cooled down before putting it back in its fixation!

11.5. Measurement record and printout



CAUTION

Data loss

Once the gas analysis is completed, transfer the values recorded in the intermediate memory to the Multi-Media-Card otherwise they could get lost by switch-off of the instrument!

--ECOM-J2KN--
Start printout
View memory
Memory -> M
Insert Text
Quit with: ↵

--ECOM-J2KN--
Start printout
View memory
Memory -> M
Insert Text
Quit with: ↵

--ECOM-J2KN--
Start printout
View memory
Memory -> M
Insert Text 
Quit with: ↵

Memory symbol

--ECOM-J2KN--
Start printout
View memory
Memory -> M
Insert Text
Quit with: ↵

Press **<Print>** (printer symbol) to enter the printing menu. The sampled data can be checked one more time („**View memory**“, **<OK>**) and scroll with the cursor keys).

The software keyboard enables the input or correction of the 6 x 20-character text. Select hereto „**Input text**“, press **<OK>** and input text (see page 13).

Press „**Memory -> M**“ and **<OK>** to store the all data -if correct- in the internal memory or on the multi-media card. Once the transfer is completed, a "**Memory symbol**" appears on the bottom right of the display. The entered text will only be recorded in the data record by use of the multi-media card.

Select „**Start printout**“ and press **<OK>** to start a printout.

Press **<ESC>** to turn back to the gas analysis menu.

11.6. Mean value measurement

By mean value measurement function measurements can be taken in an adjustable time frame and mean values can be calculated. Should the several measurement values or the mean value result be stored a storage place has to be selected as described in chapter 7. If the function “**Store**” is activated, based on this storage place all measurements will be written consecutively on the next storage places. If the function “**Store**” is not activated, the mean value result can be stored on MMC with **<Print> / „Memory -> M**.

Gas analysis
Mean value
Pressure
Soot..Oil trace
Data processing
Adjustments
Control
Diagnostics

Mean value
Start measurement
Meas. time
Scanning
Printer
Store
Quit with: ←

After run through fresh air calibration the menu point “**Mean value**” can be chosen. Before the mean value measurement can be started the settings for “**Meas.time**”, “**Scanning**”, “**Printer**” and “**Storage**” should be checked and if necessary be changed. The meanings are:

- **Meas. time** = Time frame in which the mean values will be calculated.
- **Scanning** = time between the measurements taken for mean value calculation.
- **Printer** = logging of measurements taken for mean value calculation.
- **Store** = all measurements for mean value calculations will be stored.

“**Measurement time**” and “**Scanning**” can be adjusted as follows:



1. Select menu point and confirm with **<OK>**.
2. Set the desired time with the numeric keys:
0.01 = 1sec. = minimum value.
59.59 = 59 min. : 59 sec. = maximum value.
3. Confirm with **<OK>**.

The setting for “**Printer**” can be changed as follows:

1. Select menu point and confirm with **<OK>**.
2. Select desired setting with the **cursor keys**.
3. Confirm with **<OK>**.

The setting for “**Store**” can be changed as follows:

1. Select menu point and confirm with **<OK>**.
2. Activate storage function with **<F1>** or deactivate storage function with **<F4>**.

O2	3.2 %
CO2	13.1 %
CO	0 ppm
Eff.	92.5 %
Losses	7.5 %
Exc. air	1.18
T. Gas	184.4 °C
T. Air	20.3 °C
Mean value	25.11.17
15:59 min	 

By ‘**Start measurement**’ / **<OK>** the recording of the measurement values will be started. On the display the actual mean values will be shown (will be updated with new measurement values / switch to the actual values with cursor keys **<up/down>**). It is possible to scroll through the values with the cursor keys **<right/left>**. With **<F2>** you can interrupt and with **<F4>** stop the measurement.

After the measurement time is over a protocol of the results with all mean values can be printed (key **<Print>**).

11.7. After measurement

NOTICE

Get the heated sampling system cooled down before putting it back in its case!

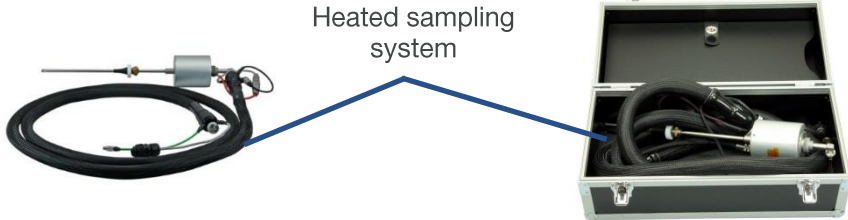

NOTICE

Fold radio antenna before closing the case!

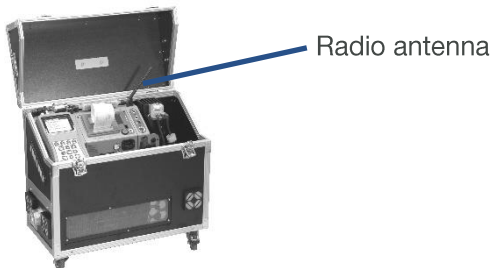

NOTICE

Please place transport protection before transport!

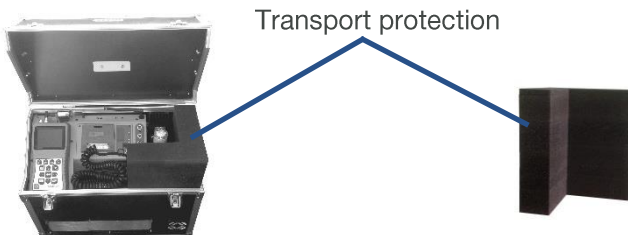

12. Adjustments

Calibr. sensors
Re-Calibration
Unit
Second unit
Ref. O2
Quit with: ←
Fuel type
Set clock
Paper feed
Internal
Tightness test

Additionally to the ecom-J2KNpro tech functions described previously, various adjustments can be made in the instrument. From the main menu select the sub-menu "**Adjustments**" and confirm with **<OK>**.

A selection of modifiable parameters, adjustable according to the application, is displayed. Set the cursor on the desired line and press **<OK>** to call up or modify the adjustment. The modifiable parameters are:

Calibr. sensors:

- CO / NO / NO2 / SO2 etc. calibration
(Important: Span gas must get pressure-free to the instrument!)
 1. Flow with span gas.
 2. Wait for stabilisation of value.
 3. By drift press **<OK>**.
 4. Set correct value with **number keys**.
 5. Confirm input with **<OK>**.
- T.Gas / T.Air calibration.
 1. Create reference temperature.
 2. By drift press **<OK>**.
 3. Set correct value with **number keys**.
 4. Confirm input with **<OK>**.
- Pressure calibration.
 2. Set draught sensor on 0 with **<F4>** key.
 3. Create reference pressure.
 4. By drift press **<OK>**.
 5. Set correct value with **number keys**.
 6. Confirm input with **<OK>**.

- Soot measurement calibration
 1. Connect suitable reference principle for volume determination
 2. Insert filter paper
 3. Confirm with <OK>
 4. Start soot measurement with <OK>
 5. After 1,63 l volume has been sucked, press again <OK> (operation time of the pump will be memorised)
- Press <ESC> to return to the main menu

Re-Calibration (Start with <OK>):

- Start of a calibration phase to set new zero-point for the sensors

Unit (adjustment with **cursor keys**):

- Calculation of gas concentrations in:
 1. ppm = volume concentration (parts per million)
 2. mg/m³ = mass concentration per volume unit
 3. mg/kWh (undiluted) = mass concentration per power unit
 4. mg/MJ (undiluted) = mass concentration per power unit
 5. ppm (undiluted) = volume concentration (parts per million)
 6. mass concentration per volume unit

Undiluted:

- Conversion of the gas concentration on selected reference oxygen
- mg/kWh and mg/MJ are always calculated on 0% O₂ basis
- Conversion formula:

$$E_{\text{ref}} = E_{\text{meas}} * \frac{21 - O_{2\text{ref}}}{21 - O_{2\text{meas}}}$$

Second unit (adjustment with **cursor keys**):

- two different unit for one gas concentration possible

Ref. O₂ (for ppm and mg/m³ units - Input after <OK> pressing):

- Input of O₂ reference value O_{2ref}

Fuel type (press <OK> to access selection list):

- Modification of adjusted fuel type (e.g., by measurements at combination plants)

Set clock (press <OK> to access setting menu):

- Correction of internal clock with cursor keys

Paper feed (press <OK> to activate paper feeding):

- Paper feed line by line

Tightness test (Start with <OK>):

- Leakage test of gas system of the ecom-J2KNpro tech
- Lock probe with a plug and start test with <OK>

Print contrast
Reload function
Key beep
Graphic menu
Probe heating
Quit with: ←
Low power mode
Language: English
F1 Hotkey
F4 Hotkey
Value options
RF-connect. only
USB
Bluetooth
WLAN
Pitot factor
Printout

Internal (press <OK> to open menu):

- Further instrument settings:

Printout contrast (0..9)

(press <OK> to access input menu):

- Printer contrast adjustment

Recharging function

(<F1> for ON / <F4> for OFF):

- Recommended setting = OFF

Key beep (<F1> for ON / <F4> for OFF):

- Acoustical signal by key pressing

Graphic menu (<F1> for ON / <F4> for OFF):

- Activation of graphic mode

Low power mode (<F1> for ON / <F4> for OFF):

- Switching on / off the probe heating and the gas cooler at battery operation

Probe heating (<F1> for ON / <F4> for OFF):

- ON/OFF switch for probe heating for soot measurement

Language: English (switch with <OK>):

- -Info about used language (3 languages selectable)

F1 Hotkey (Choose after pressing <OK>):

- Change the menu you get to after pressing <F1> in value display

F4 Hotkey (Choose after pressing <OK>):

- Change the menu you get to after pressing <F4> in value display

Value options (Change with <OK>):

- Temperature in °C or °F (not possible at all instruments)
- Excess Air as proportionate number or in %
- Calculation of efficiency with and without condensation
- Pressure in hPa, mmH₂O, "H₂O, PSI, mbar (not possible at all instruments)

RF-connect. only (Choose after pressing <OK>):

- **Standard:** no radio connection if control module is located in basic module
- **RF-connect. only:** radio connection also if control module is located in basic module
- **Remote:** without function

USB (selection after pressing <OK>):

- Adjustment of transfer speed (Cursor keys <Up/Down>)
- Adjustment of transfer speed (Cursor keys <Right/Left>):
 - Protocol DAS = Protocol for the program DASNT
 - Protocol Enhanced = Protocol for the program DAS5

Bluetooth LE (<BLE> no adjustment needed):

- Online data = Remote

WLAN (selection after pressing <OK>)

Instrument as Access Point (for connection with mobile terminals):

- **(Start/Stop WLAN:** manual switching of WLAN connection – available only with deactivated Auto Connect)
- **Access Point:** (<F1> for ON / <F4> for OFF)
- **(W.O.) Auto Connect:** Automatically connection (<F1> for ON / <F4> for OFF)
- **Security:** use password for connection (<F1> for ON / <F4> for OFF) the password is „1234567890“
- **Channel:** Input channel (1 – 13) (selection after pressing <OK>)

Connection with existing network:

- **(Start/Stop WLAN:** manual switching of WLAN connection – available only with deactivated Auto Connect)
- **Existing Network:** available only with deactivated Access Point
- **(W.O.) Auto Connect:** Automatically connection (<F1> for ON / <F4> for OFF)
- **Network scan:** Search for available networks (selection with <OK>)
- **WPA password:** Input of password for selected network

Pitot factor (selection after pressing <OK>):

- Input of pitot factor for flow rate calculation (ecom flow probe = 0.93)
- If the value is set to 0, no calculation is performed

Printout (selection after pressing **<OK>**):

- Text input for printout on measurement protocol (8 x 24 characters)
- Input the text of line 1 as follows:
 1. Activate character selection list with **<OK>**.
 2. Select keyboard type with **<F3>** (4 different keyboards available).
 3. Use the cursor keys to select the desired character (selected character is outlined by black background).
 4. Confirm selection while pressing **< OK >**.
 5. Repeat procedure until desired text is complete.
 6. Once input for line 1 is completed, deactivate the characters selection mode with **<F1>** and move to the second line with the cursor key **<Down>**.
 7. Once all lines have been processed as desired, exit the menu with **<ESC>**.

13. Control

The sensors alter their output values along the operation period. The programme controls the sensors and corrects drifts. If the drifts and the correlated measurement errors increase, an error message is displayed. In this case the corresponding sensor must be changed by an authorised service centre. The control menu informs about the current status values for the sensors as well as about (page 2 and 3 with cursor keys <up/down>):

The image shows three sequential screenshots of the 'Control' menu. The first screenshot displays contact information (Tel., Fax, eMail) and sensor voltages (CO2, CO, Batt., Bat.B). The second screenshot shows operation hours, serial number, service contact, program version, and next unit check, along with sensor readings (CO2, CO, Batt., Bat.B) and error counts (1 X, 22 ppm, 4 X, 11 X). The third screenshot shows the last service history (date, count, status) and sensor voltages.

1	Next service centre	6	Number of frames (USB)	11	Recommended maintenance date
2	Serial number	7	Date of last service	12	Number of CO-switch -offs
3	Software version	8	Sensor voltages	13	ppm hours of CO sensor
4	Radio quality	9	Batt. voltage basic / control module	14	Number of errors
5	Sent frames / Received frames	10	Operation hours	15	Number of instrument switch-ons

Info display:

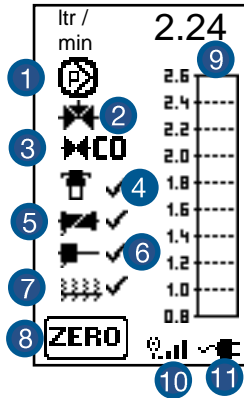

1	Gas pump is running	5	Heated hose ready for use	9	Gas flow (litre per minute)
2	Air valve is open	6	Heated head ready for use	10	Radio mode
3	CO purging is running	7	Sensors ready for use	11	Mains operation
4	Gas cooler ready for use	8	Calibration phase is running		

14. Data Processing

14.1. Communication

If a MM card is inserted in the slot, so it will be used as record medium. The menu „**Data processing**“ offers the following functions:

Select		
View		
Memory (M)		
DRT <-> PC !		
Format		
Quit with: ←		
Automatic measu.		

Date	Time	Fuel type
1 01.09.17	11:01:24	Fuel oil
2 01.09.17	11:02:34	Fuel oil
3 01.09.17	11:04:20	Fuel oil
4 01.09.17	11:07:44	Fuel oil
5 01.09.17	11:11:25	Fuel oil
6 01.09.17	11:23:02	Fuel oil
7 01.09.17	11:44:09	Fuel oil
8 01.09.17	11:53:13	Fuel oil
9 01.09.17	11:59:59	Fuel oil
10 01.09.17	11:59:59	Fuel oil
Select:	⏮⏪⏩⏭	

Select:

For search or creation of plants files for measurement values assignment (compare chapter “Input or selection of combustion plants”).

View:

Recorded values to a selected plant can be viewed (compare chapter “Input or selection of combustion plants”).

Memory (M):

Here all stored measurements (sorted by record number) can be seen. Individual measurement values can be called as follows:

1. Choose record number with the cursor keys and confirm with <OK>.
2. Scroll with the cursor keys.
3. Leave record number with <ESC>.

DRT <-> PC !
Send data
Load data
Quit with: ←

DFÜ <-> PC!:

Load data:

Enables the data import with USB cable from e.g., ecom software “miniDV” (available on our website „www.ecom.de“). See chapter „Technical Data“ for data format information (please observe the transfer options of your software!).

Proceed as follows:

1. Connect ecom-J2KNpro tech and PC via USB cable.
2. Select “**Load data**“ and confirm with **<OK>**.
3. Answer the displayed question with **YES (<F1>)**.
4. Decide if the data recorded can be cancelled (**<F1>** for **YES** / **<F4>** for **NO**).
5. Start the data transfer on your PC.

Send data:

With this function the data records completed with measurement values can be transferred to the PC programme (procedure similar to chapter „**Load data**“).

Format:

This function is usually needed by the initial adjustment of the instrument at our factory (preparation of internal memory for data record).

Caution: All stored values will be cancelled!

14.2. Automatic measurement

The configuration of the ecom-J2KNpro tech with operation securing, self-regulating additional components like the condense trap, the gas cooler and the magnetic valve technique permits even a long-term operation of the instrument. By setting time intervals for the measurement the instrument switches autonomously to fresh air purge after the measurement phase (gas will be sucked via the connection fresh air) and operates a calibration phase for the sensors.

Automatic measu.	
Automatic	
Data logger	
Automatic time	120 min
Measurem. time	115 min
Save to MMC	1 sek
CSV+Header	
Quit with:	←

This cycle repeats itself until the automatic measurement will be finished. For setting the time intervals select from the menu “**Data processing**” the menu item “**Automatic measu.**”. The time intervals have following meanings:

Automatic time (min. 10 minutes / max. 120 minutes)

Time interval from one calibration phase to the next one.

Measurement time (max. Automatic time minus 5 minutes)

Time interval within the automatic time in which the instrument gathers measurement values, i.e., in which the measurement gas will be sucked. The difference between the measurement time and the automatic time is used for purging the sensors with fresh air.

Save to MMC (min. 1 second / max. 255 seconds)

Adjustment of the interval time for data logger recordings.

CSV+Header (<F1> for ON / <F4> for OFF)

Adjustment of data logging with or without column headings.

Start the automatic measurement by setting the cursor to line “**Automatic**” and pressing the key <OK> (on top right on the display appears “**A**” for automatic).

14.3. Data logger

Here a Data logger record (“**Data logger**” and key <OK> / on top right on the display appears the disk symbol) can be started or finished (just available when using the multi-media card). With <Memory> you can interrupt and continue the record (only in gas analysis). For each recording one file will be written on the card. The files will be numbered consecutively (J2KDL-00.csv, J2KDL-01.csv and so on) and can be transferred to PC with a card reader. The length of a dataset is 500 byte which means that on 32 MB card 64000 measurements could be recorded.

14.4. Data logging with DASNT2

In addition to data logger recordings the data could also be transferred online via USB, Bluetooth (option) or via data interface to the software "**DASNT2**". For the USB connection, a driver is required. Software and USB driver are available free of charge from the ecom website. The following transfer parameters must be set at ecom-J2KNpro TECH ("**Adjustments**" / "**Internal**" / "**USB** "):

- **1200 Baud**
- **Protocol DAS**

Please note the hints in the software manual.

14.5. Data processing with DAS5

To display and storage of measured values and measured value gradients the software "**DAS5**" is available. With the help of a multi-media card customer and measurement data can be exchanged between software and instrument. An online connection to store measured values and measured value gradients is possible with USB or WLAN. For the USB connection, a driver is required. Software and USB driver are available free of charge from the ecom website. The following transfer parameters must be set at ecom-J2KNpro TECH ("**Adjustments**" / "**Internal**" / "**WLAN**"):

- **1200-38400 Baud** (setting as in the software "**DAS5**")
- **Protocol Enhanced**

For the wireless connection (WLAN), the following transfer parameters have to be set at ecom-J2KNpro TECH ("**Adjustments**" / "**Internal**" / "**WLAN**"):

- **Access Point = ON**
- **Auto Connect = ON**

Please note the hints in the software manual.

14.6. Data processing with App

To display and storage of measured values, the App “**ecomMANDER**” for smartphones (iOS or Android) is available. Test results are stored along with customer information in a pdf-file and can be sent e.g., as email attachment. Links to free download of the App can be found on the ecom website. For the wireless connection (WLAN), the following transfer parameters must be set at ecom-J2KNpro TECH (“**Adjustments**” / “**Internal**” / “**WLAN**”):

- **Access Point = ON**
- **Auto Connect = ON**

15. Diagnostics

15.1. Fault diagnostic

The ecom-J2KNpro tech is able to receive and to process information sent via cable by the ecom-AK (read-out head for digital firing automats). In the main menu select the sub-menu "Fault diagnosis" and confirm with <OK>. The ecom-J2KNpro tech tries to get into contact with the ecom-AK (message: „Searching“) Once the connection is realized, the current operation stand of the burner is shown graphically on the display. The operation stand can be recorded (max. 100 sec). Press <OK> to start a new recording phase (reset).

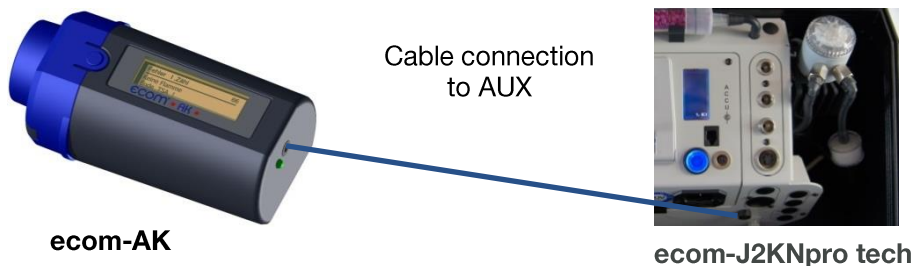

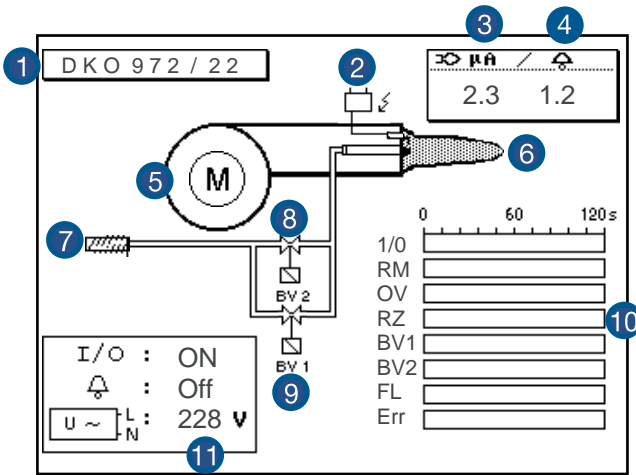

Recording of operation
(max. 100 sec):

1/0 = Continuous phase
 RM = Fan motor
 OV = Oil preheater
 RZ = Ignition
 BV1 = Valve 1st stage
 BV2 = Valve 2nd stage
 FL = Flame identified
 Err = Error

Reset = Start a new recording (press <OK>)

1	Model name	5	Engine on	9	Valve 2 is on
2	Ignition is active	6	Flame identified	10	Recording of operation
3	Current flame signal	7	Oil preheater / pressure switch on	11	Operation voltage
4	Minimum flame signal	8	Valve 1 is on		

Use the <Up/Down> keys to call up further data of the firing automat. The 2nd display page lists information about the disturbance history (type and volume of information depending on firing automat).

Error history		
1	Number of starts total	677
	Service counter actual	142
2	No error	
3	No flame at the end of safety time	004 9:23 min 0.0 µA 227 V
	Flame signal during Straylight check	001 12 sec 2.2 µA 225 V
4	Total	: 46
	Straylight	: 22
	Safety time	: 9
	Loss of flame	: 17
	FT/LW	: 0

The 3rd display page lists information about the monitoring times (type and volume of information depending).

Timing values	
	Safety time 4.9 sec
	Delay time valve 2 40.0 sec
	Pre-ignition time 17.0 sec
	Post-ignition time 20.0 sec
	Delay straylight sup. 11.5 sec
	Straylight supervision 5.0 sec
	Rest time TSA 4.1 sec
Further pages: 	

1	Number of burners starts	3	List of last errors	5	Monitoring times
2	Current error	4	Error statistics		

15.2. dT measurement

With the ecom-J2KNpro tech a difference temperature measurement is possible. For measurements at pipes (e.g., in and out of heating systems) special temperature sensors are needed, that can be ordered from your responsible ecom distributor.

dT measurement			
T1	70.4	°C	
T2	56.3	°C	
dT	14.1	°C	
dT measurement recorded!			25.11.17

 Measurement stored in intermediate memory

Select from the main menu point "**Diagnos-tics**" the submenu "**dT measurement**" and confirm with **<OK>**.

The instrument indicates the temperature T1 (sensor at connection „gas temperature“), the temperature T2 (sensor at connection „air temperature“) and the difference of both temperatures (T1 - T2). With the key **<Memory>** the result of the measurement are stored in intermediate memory. A printout can be started with **<Print>**.

16. Maintenance Tipps

⚠ CAUTION

Loss of warranty
Service made by service centres not authorised by ecom GmbH will result in a complete and immediate loss of any warranty!

To secure the accuracy of your measuring instrument we recommend the annual check by an authorized ecom partner. All ecom partners are listed under www.ecom.de. The following advices will be of help for the daily check and maintenance of single parts or assemblies:

Sample gas filter



1	PTFE filter 1	3	Fine dust filter	5	Pre filter heated head
2	SO ₂ / NO _x filter	4	Safety filter	6	PTFE filter 2

PTFE filter 1



Check the state of the PTFE filter. Change it once the filter has a grey colour (number 2-3 of the soot comparison scale).

SO₂/NO_x filter (only with electrochemical CO sensor)



In the tubing leading to the electrochemical CO sensor on the top of the instrument there is a chemical filter for filtering SO₂ and NO_x out of the flue gas. The filter material is manganese-4-oxide granules and should be changed once it has turned grey (colour change: pink> brown> black> grey> white).

Fine dust filter



Screw off the cover of the gas cooler 1 and check the state of the fine dust filter. Change it once the filter has a grey colour (number 2-3 of the soot comparison scale).

Safety filter



Check the state of the safety filter. Change it once the filter has a grey colour (number 2-3 of the soot comparison scale).

Pre filter heated head

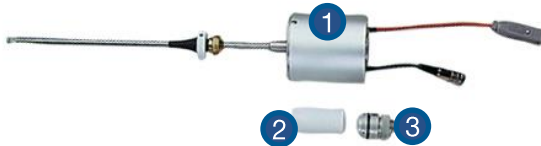

1	Heated head	2	Pre filter PTFE / 2 µm	3	Filter holder with bayonet lock
---	-------------	---	---------------------------	---	------------------------------------

Loosen the bayonet lock (press and turn it 90 °) and check the state of the pre filter. It should be changed when the filter (inside) has a grey colour (number 2-3 of the soot comparison scale).

PTFE filter 2



Screw off the cover and check the state of the PTFE filter. Change it once the filter (outside) has a grey colour (number 2-3 of the soot comparison scale).

Ventilation filter



1 No ventilation filter	2 Ventilation filter type 1	3 Ventilation filter type 2
-------------------------	-----------------------------	-----------------------------

Ventilation filter type 1

The ventilation filter should be changed, if the filter is grey coloured (number 2-3 of the soot comparison scale). Remove for this the filter holder (pull it off). Change the filter cartridge and fasten the filter holder.

Ventilation filter type 2

The ventilation filter should be changed, if the filter is grey coloured (number 2-3 of the soot comparison scale). Remove for this the filter holder with the help of a screw driver (recesses on the right of and left side). Change the filter cartridge and fasten the filter holder.

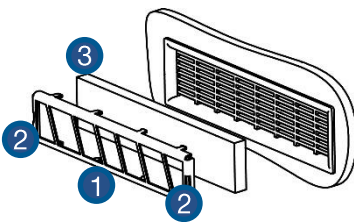

1 Filter holder	2 Recesses	3 Filter cartridge
-----------------	------------	--------------------

Sensors

The sensors get calibrated with the reference gas fresh air by each switch-on procedure. The state of the sensors is permanently controlled by the instrument. If an error message is displayed during calibration and cannot be eliminated despite several calibration phases, so the instrument must be checked by a qualified and authorised service centre.

Probe and hose (only probe type SB)

Depending on the frequency of use, probe and hose should be regularly cleaned in order to release particle deposits and to prevent early wearing due to corrosion:

1. Release the connections at the instrument and at the probe grip to free the hose.
2. Clean the hose (flow warm water in then dry respectively blow water drops out).
3. Lubricate hose connector O-rings occasionally with non-acidic lubricant.

Printer

Change printer roll as follows:

1. Release the printer cover.
2. If necessary, extract the paper rest out of the printer ("**Adjustments**" / "**Paper feed**" / <OK>).
3. Remove the printer shaft and place the new paper roll on the printer shaft.
4. Insert the paper end in the slot (future printed side must be ahead).
5. Press ("**Adjustments**" / "**Paper feed**" / <OK>) to transport ± 10 cm paper thru the printer.
6. Place the printer shaft back in the fixation.
7. Insert the paper thru the cover of the printer compartment.
8. Close the printer compartment while fixing the cover.

17. FAQ

FAQ	
Where do I find important instrument information?	In the menu „Control“ all important instrument information is shown (e.g., battery voltage, sensor values, unit number, next service date, operation hours etc.). With the arrow keys stands you can switch to the second page.
The instrument shows the error message „O2 sensor 0 mV“!	The sensor must be renewed.
The instrument shows the message „Check required“!	This message appears automatically every 12 months. Note: This is a recommendation to let check the instrument. The instrument is however still ready for use.
The instrument shows the error message „T-Gas“ or „T-Air“!	<p>Possible reasons could be:</p> <ul style="list-style-type: none"> • Cable is broken (at the plug). • T-Air sensor is broken. • Thermocouple is broken. • Cable is defective. <p>Note: The error messages can be ignored at the J2KNpro TECH by pressing „OK“. Calculations that depend on these temperatures are not implemented.</p>
The instrument shows wrong or inaccurately CO2 values!	<p>Possible reasons could be:</p> <ul style="list-style-type: none"> • O2 is defective (CO2 values are calculated from the O2 values). • Pump is not working correctly. • Leakage in the gas way. • Condensate trap / gas cooler is clogged.
My instrument cannot be switched on!	<ul style="list-style-type: none"> • Please check the mains cable. • Please check the fuse. • Please check mains connection (Plug socketswitched on?). • Please load the accumulator min. 8 hours (Accumulator could be over-discharged).
My instrument does not print!	Please check whether the printer paper is correctly inserted. The thermal printer writes only on the

	thermally sensitive side. Please use always the correct paper for the printer, you will prevent defects at the printer. Please make sure that the printer is clean (no chads in the drive).
Can I change the printout?	You can change the printout (Menu: "Adjustments").

18 Technical Data

Parameter	Range	Principle
O ₂	0 - 21 vol. %	Electrochemistry
CO (Option)	0 - 1000 ppm	Infrared
CO (Option)	0 - 10000 ppm	Electrochemistry
CO% (Option)	0 - 6,3 vol. %	Electrochemistry
CO% (Option)	0 - 6,3 vol. %	Infrared
NO (Option)	0 - 1000 ppm	Chemiluminescence
NO (Option)	0 - 5000 ppm	Electrochemistry
NO ₂ (Option)	0 - 1000 ppm	Photoacoustic
NO ₂ /SO ₂ (Option)	0 - 100 (2000) ppm	Ultraviolet
NO ₂ (Option)	0 - 1000 ppm	Electrochemistry
SO ₂ (Option)	0 - 1000 ppm	Infrared
SO ₂ (Option)	0 - 5000 ppm	Electrochemistry
H ₂ S (Option)	0 - 1000 ppm	Electrochemistry
H ₂ (Option)	0 - 2000 ppm	Electrochemistry
CO ₂ (Option)	0 - 20 vol. %	Infrared
CO ₂	0 - CO ₂ max	Calculation
T-Gas	0 - 500 °C	NiCr/Ni
T-Air	0 - 99 °C	Semi-conductor
Differential pressure	0 - +/- 100 hPa	DMS bridge
Air pressure	300 - 1100 hPa	DMS bridge
Efficiency	0 - 120 %	Calculation
Losses	0 - 99,9 %	Calculation
Excess air	1 - ∞	Calculation
Ref. O ₂ adjustable	0 - 21 vol. %	Calculation
Flue gas dew point	x °C	Calculation

Further Data	
Power supply	Mains power 230 V / 50 Hz~; Batt. 7,20 V / 11,6 Ah
Printer	58mm Paper width
Dimens. (L x H x D)	525 x 845 x 270 mm
Weight	ca. 34 kg with heated sampling system
Application limits	+5 - +40 °C max. 90 % rF, non-condensing

NOTICE

Subject to technical changes! (Stand 05.2022)

Description of data record ecom-J2KNpro tech / Multi-Media-Card
 Format data logger records J2KDL-xx.csv
 (Separation mark between values = comma)

Column	Description	Remark
A	Datum	also, US-Version
B	Zeit	also, US-Version
C	O2 in vol.%	0,0 - 21,0
D	CO in ppm	0 - 10000
E	NO in ppm	0 - 5000
F	NO2 in ppm	0 - 1000
G	SO2 in ppm	0 - 5000
H	CO (Unit 1)	
I	NO (Unit 1)	
J	NO2 (Unit 1)	
K	NOx (Unit 1)	
L	SO2 (Unit 1)	
M	T.Gas in °C or °F	US-Version °F
N	T.Air in °C or °F	US-Version °F
O	Draught in hPa	0,00 - +/- 100,0
P	CO2 in vol.%	0,0 - 25,0
Q	Efficiency in %	0,0 - 120,0
R	Losses in %	0,0 - 100,0
S	Excess air	> 1,00
T	Dew point in °C or °F	US-Version °F
U	Poisoning index	> 0,0
V	O2 (gas channel check) in vol.%	0,0 - 21,0
W	CO (gas channel check) in ppm	Related to 0,0 vol.% O2
X	CO (gas channel check) in ppm	Measured value
Y	O2 (O2 check) in vol.%	0,0 - 21,0
Z	T.Boiler in °C or °F	US-Version °F
AA	T.Sensor in °C or °F	US-Version °F
AB	O2 reference	0,0 - 21,0
AC	Unit 1	0=ppm; 1=mg/m3; 2=mg/kWh; 3=mg/MJ
AD	Norm	N = converted to O2 reference
AE	Fuel type number	Index acc. to instrument table
AF	Fuel type text	Text acc. to instrument table
AG	Soot number 1	0,0 - 9,9
AH	Soot number 2	0,0 - 9,9
AI	Soot number 3	0,0 - 9,9
AJ	Oil trace	0=no; 1=yes;
AK	20 character text	
AL	20 character text	
AM	16 character text	

AN	Serial number	
AO	CO (O2 check) in ppm	
AP	Draught (O2 check) in hPa	
AQ	CxHy in ppm or vol. %	
AR	Number copy data	
AS	T1 (dT measurement) in °C or °F	US-Version °F
AT	T2 (dT measurement) in °C or °F	US-Version °F
AU	Velocity in m/s	
AV	CO Environment in ppm	CH-Version = Kind of control
AW	free	CH-Version = Load range
AX	Comment text 1	
AY	Comment text 2	
AZ	Comment text 3	
BA	Comment text 4	
BB	H2 in ppm	CH-Version = Oil consumption
BC	H2 (Unit 1)	CH-Version = Thermal output
BD	Sensor 6 in ppm	CH-Version = Operation hours counter
BE	Sensor 6 (Unit 1)	CH-Version = Code
BF	dP (velocity) in Pa	0 – 1000,00
BG	Air pressure in hPa	300 – 1100
BH	Unit 2	0=ppm; 1=mg/m3; 2=mg/kWh; 3=mg/MJ; 4=ppmN; 5=mg/m3N; 6=---
BI	CO (Unit 2)	
BJ	NO (Unit 2)	
BK	NO2 (Unit 2)	
BL	NOx (Unit 2)	
BM	SO2 (Unit 2)	
BN	Analogue output 1	
BO	Analogue output 2	
BP	Sensor 7 in ppm	
BQ	Meas. gas volume in l/min	
BR	CO%	
BS	Last column	0

Data transfer ecom-J2KNpro tech to PC (USB)

The transfer occurs with 1200 - 38400 BAUD; 1 stop bit; no parity (ANSI character set)

CR / LF is send after each data record

Column	Description	Length
1-5	Storage number	5
6-7	Hour	2
8-9	Minute	2
10-11	Day	2
12-13	Month	2
14	Fuel type number (0 – 9)	1
15-19	T.Air in °C or °F	5
20-24	T.Gas in °C or °F	5
25-29	O2 in vol.% (without comma)	5
30-34	CO in ppm	5
35	Draught (sign / - = minus; blank character = plus)	1
36-39	Draught in Pa	4
40	Oil trace (0 = no; 1 = yes)	1
41	Soot 3	1
42	Soot 2	1
43	Soot 1	1
44-48	free	5
49-53	NO in ppm	5
54-58	T.Boiler	5
59-78	20 character text (1st display line)	20
79-98	20 character text (2nd display line)	20
99-114	16 character text (3rd display line)	16
115-116	2 signs (HEX \$80, \$00)	2
117-121	O2 (CO measurement) in vol.% (without comma)	5
122-126	CO (CO measurement) in ppm related to 0,0 vol.% O2	5
127-131	free	5
132-136	free	5
137-141	free	5
142-146	free	5
147-151	free	5
152-156	O2 (O2 check) in vol.% (without comma)	5
157-161	CO (O2 check) in ppm	5
162	Draught (O2 check / sign / - = minus; blank character = plus)	1
163-166	Draught (O2 check) in Pa	4
167-168	CR-LF (#13#10)	2

Data transfer PC to ecom-J2KNpro TECH (ANSI character set):

First send: \$00 \$01

Then send: 56 characters text

Then send: \$80 \$00

Once the ecom-J2KNpro tech has processed the data, it sends \$FF back. If the data volume is too large, it sends another byte back. If the data transfer should be terminated, so just 60 byte \$00 need to be sent to the instrument.

INTELLIGENT MESSEN!
MEASURE WITH INTELLIGENCE!



ecom GmbH

Am Großen Teich 2

D-58640 Iserlohn

Info@ecom.de

www.ecom.de

Telefon:+49 2371 945-5

Fax: +49 2371 40305